

REPLACEMENT

CAUTION:

- Prolonged and repeated contact with mineral oil will result in the removal of natural fats from the skin, leading to dryness, irritation and dermatitis. In addition, used engine oil contains potentially harmful contaminants which may cause skin cancer.
- Exercise caution in order to minimize the length and frequency of contact of your skin to used oil. Wear protective clothing and gloves. Wash your skin thoroughly with soap and water, or use water-less hand cleaner, to remove any used engine oil. Do not use gasoline, thinners, or solvents.
- In order to preserve the environment, used oil and used oil filter must be disposed of only at designated disposal sites.

1. DRAIN ENGINE OIL

- Remove the oil filter cap.
- Remove the oil drain plug, and drain the oil into a container.

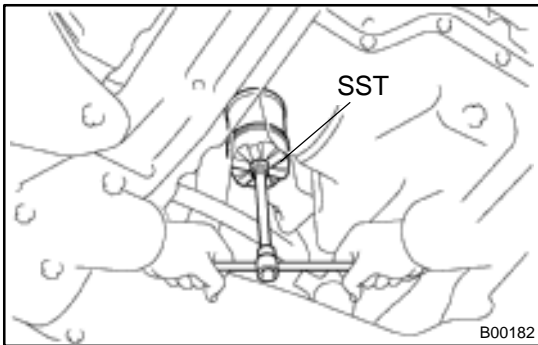

2. REPLACE OIL FILTER

- Using SST, remove the oil filter.
SST 09228-06501
- Check and clean the oil filter installation surface.
- Check the part number of the new oil filter is as same as old one.
- Apply clean engine oil to the gasket of a new oil filter.

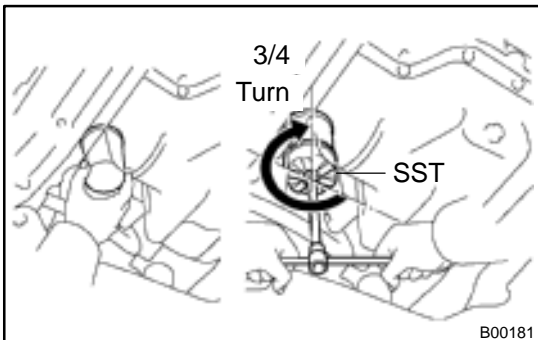

- Lightly screw the oil filter into place, and tighten it until the gasket contacts the seat.
- Using SST, tighten it an additional 3/4 turn.
SST 09228-06501

3. REFILL WITH ENGINE OIL

- Clean and install the oil drain plug with a new gasket.
Torque: 37 N·m (378 kgf·cm, 27 ft·lbf)

(b) Fill with fresh engine oil.

Capacity:

Drain and refill w/ Oil filter change	3.7 liters (3.9 US qts, 3.3 Imp. qts)
w/o Oil filter change	3.5 liters (3.7 US qts, 3.1 Imp. qts)
Dry fill	4.2 liters (4.4 US qts, 3.7 Imp. qts)

(c) Install the oil filler cap.

4. START ENGINE AND CHECK FOR OIL LEAKS

5. RECHECK ENGINE OIL LEVEL